

Tension/compression force transducer With external thread, universal, very small diameter

with electrical output



Description

The range of applications for this load cell covers countless industrial applications where high accuracy, simple installation play a decisive role. The dimensions of the load cell have been kept exceptionally compact, so that it can be easily incorporated in existing facilities or installed in poorly accessible locations.

The compression or tension forces are transmitted via the two threaded pins into the cylindrical casing, which is also the measuring element.

The force to be measured must be applied concentrically along the central axis as far as possible. Bending and torsion moments can lead to permanent damage to the load cell.

Note

In order to avoid overloading, it is advantageous to connect the load cell electrically during installation and to monitor the measured value.

The force to be measured must be applied concentrically and free of transverse force. The load cells are to be mounted on a level surface.

Features

- for tension and compression force measurements
- simple force introduction
- compact small dimensions
- simple installation
- Protection class IP 65
- Accuracy 0.3% of full scale value

Measuring ranges

- 1 kN ... 100 kN

Applications

- Plant engineering
- Machine tool construction
- Measurement and inspection equipment
- Test benches and production lines

Model: F2216

Technical data

Model	F2216		Options
Nominal load F_{nom}	1, 2, 5, 10, 20, 50, 100 kN		≤± 0.25% of F.S., with tension force only
Accuracy class	tension	0.3% of F.S.	
	tension and compression	0.5% of F.S.	
Limit load	150% F_{nom}		
Breaking load	>300% F_{nom}		
Combined error	≤± 0.5% of F.S.		
Max. dynamic load	± 70% F_{nom} acc. to DIN 50100		
Creep, 30 min. at F_{nom}	<± 0.1% of F.S.		
Nominal deflection	< 0.1 mm		
Nominal temperature range	0 ... +50°C		
Service temperature range	-10 ... +60°C		
Storage temperature	-30 ... +90°C		
Reference temperature	23°C		
Temperature influence	-span	±0.2% of F.S. / 10K	
	-zero	±0.2% of F.S. / 10K	
Protection type (acc. to EN 60 529/IEC 529)	IP 65		
Insulation resistance	> 2 GΩ		
Analogue output			
- Output signal	0.8 ... 1.2 mV/V		
- Bridge resistance	350 Ω		
- Option	Cable integrated amplifier 0 (4) ... 20 mA, 0 ... 10 V DC		
- Tolerance of span	≤± 0.3% of F.S.		
- Excitation voltage	2 ... 12 V (max. 15 V) up to 10 kN: 2 ... 6 V (max. 8 V), 16 ... 32 V DC for cable integrated amplifier		
- Electrical connection	Cable 3 m / 4-wire		
Material of measuring device	Stainless steel		
Weight (kN)			
- 1 - 2	0,05 kg		
- 5	0,06 kg		
- 10	0,08 kg		
- 20	0,11 kg		
- 50	0,18 kg		
- 100	0,3 kg		

of F.S. = full scale value

Dimensions

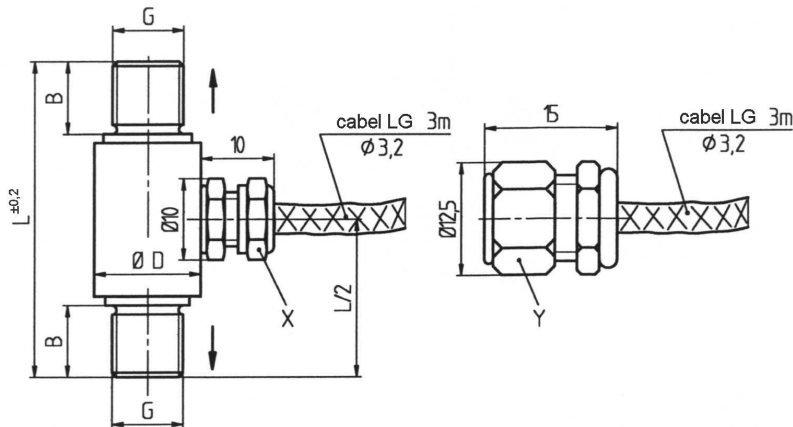

Nominal load [kN]	Dimensions in [mm]					
	L	G	ØD	B	X	Y
1, 2	35	M 5	10	8	•	---
5	35	M 8	12	8	•	---
10	40	M 10	18	10	•	---
20	45	M 12	24	12	•	---
50	50	M 16	29	15	•	---
100	70	M 24 x 2	35	20	---	•

Electr. connection	
Excit. (-)	green
Excit (+)	brown
Sign. (+)	yellow
Sign. (-)	white
Control	grey
screen	screen

Subject to technical changes