

Pressed-in sensor with integrated amplifier

Accuracy: $\leq 2\%$ depending on installation
Output signals: 4...20 mA; 2-wire system,
or
0...10 VDC 3-wire system,

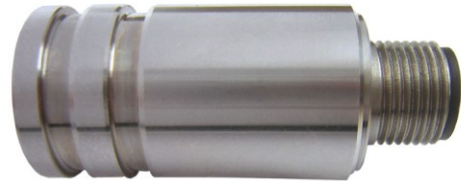

Description

The pressed-in sensor has been developed for applications where deformations caused by external forces are to be measured in existing components. Due to the press-fit method, installation is simple and an existing component is given the properties of a force transducer.

The pressed-in sensor can be used in existing structures from a material thickness of 4 mm and a tensile strength of $> 350 \text{ N/mm}^2$. It is suitable for use in structures with a strain of $0,1\% \leq \varepsilon \leq 0,25\%$. The pressed-in sensor contains an integrated programmable digital amplifier. After fitting the sensor, zero point and sensitivity are set using the tecs is handheld programming unit (EPE01). This makes a standardised mA or V signal available. Depending on the installation, an overall accuracy of $< 2\%$ F.S. scale range is achieved.

This pressed-in sensor uses an implanted thin film. Thin film sensors, manufactured using advanced technologies, have all advantages of conventional film strain gauges, but without their considerable disadvantages (temperature response of the adhesive and creep).

The force transducer meets EN 61326 for electromagnetic compatibility (EMC).

Features

- Implanted thin film
- Corrosion resistant stainless steel design
- Integrated amplifier
- High long-term stability
- High shock and vibration strength
- For dynamic and static measurements
- Good repeatability
- Easy to install

Measuring ranges

- Elongations from $0,1\% \leq \varepsilon \leq 0,25\%$

Applications

- Hoists, cranes
- Tool approach load machines
- Manufacturing automation
- Machine and plant building
- Container weighing
- Fill level control

Model: F9303

Principle of operation

When a mechanical structure is subjected to a load, its shape changes. If a hole is placed at a suitable position, this also deforms. Under strain the round hole becomes an oval hole. The press-fit sensor deforms in the same way and thus very accurately records the resultant compressive, tensile and shear stresses.

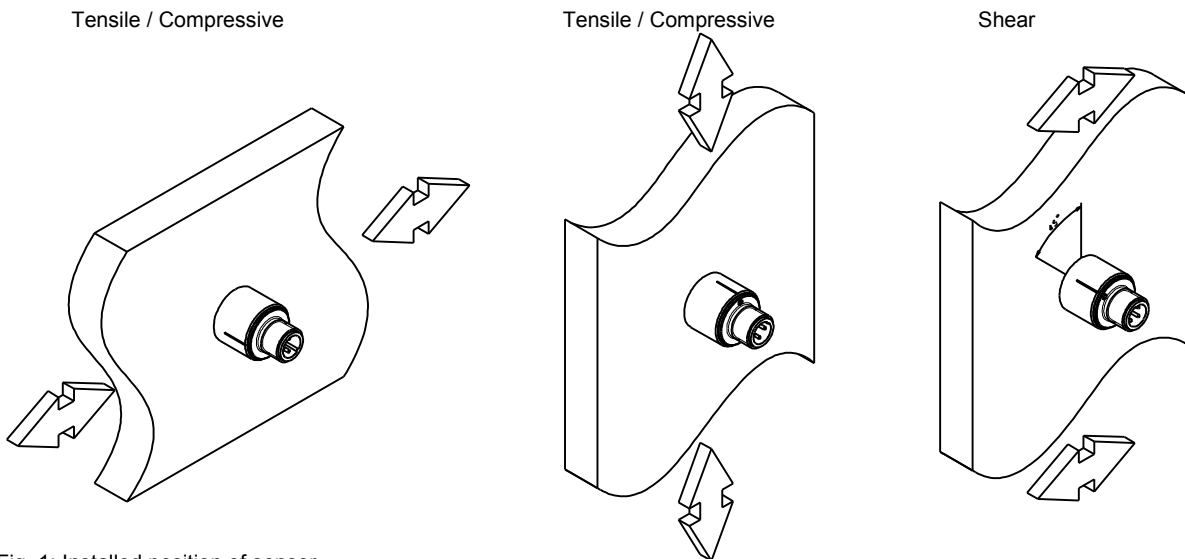

Fig. 1: Installed position of sensor

Specification

Model	F9303	
Elongation ϵ	$0,1\text{‰} \leq \epsilon \leq 0,25\text{‰}$	
Limit elongation	150 % ϵ_{nom}	
Combined error	$\leq \pm 2\%$ of F.S., depending on assembly situation	
Hysteresis	$\leq \pm 0,5\%$ of F.S., depending on surrounding steel	
Creep, 30 min. at ϵ_{nom}	< 0.5 % of F.S., depending on surrounding steel	
Nominal temperature range	-20 ... +80°C	
Service temperature range	-40 ... +80°C	
Storage temperature range	-40 ... +85°C	
Temperature effect - span - zero	typ. $\pm 0,5\%$ of $\epsilon_{nom} / 10K$ typ. $\pm 0,5\%$ of $\epsilon_{nom} / 10K$	each one depending on material pair
Vibration resistance (acc. to DIN EN 60068-2-6)	20g, 100h, 50...150 Hz	
Protection type (acc. to EN 60529/IEC 529)	IP 67	
Noise emission	acc. to EN 61326	
Noise immunity	acc. to EN 61326	
Insulation resistance	> 5 G Ω / 50 V	
Electrical protection	Reverse voltage, overvoltage and short circuit protection	
Analogue output		
- Output signal	4 ... 20 mA; 2-wire; 0 ... 10 V; 3-wire	
- Current consumption	Current output: signal current; Voltage output approx. 8 mA	
- Power requirement	10 ... 30 V DC for current output; 14 ... 30 V DC for voltage output	
- Burden	$\leq (U_B - 6V) / 0,024\text{ A}$ for current output; > 10 k Ω for voltage output	
- Response time	$\leq 1\text{ ms}$ (within 10% ... 90% ϵ_{nom})	
- Electrical connection	Circular connector M 12x1, 4-pin	
Material of measuring device	Stainless steel	

of F.S. = full scale value

Dimension

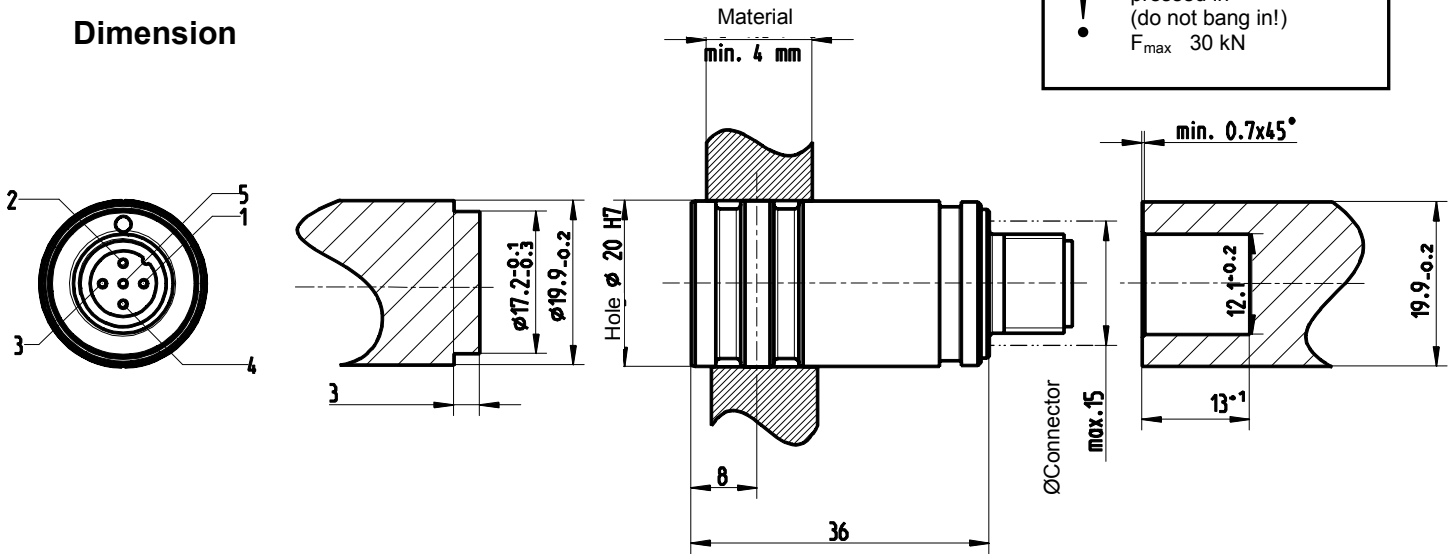

Note alignment of notch during press in process!

Electrical connector

4...20 mA output (2-wire system)

M12x1 round connector, 4 pole

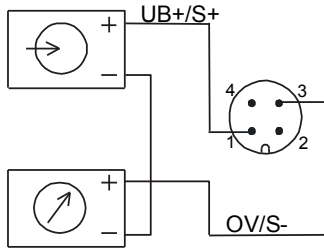

940E01

Cable out

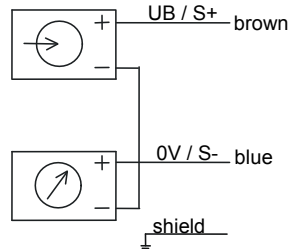

940E03

0...10V output (3-wire system)

M12x1 round connector, 4 pole

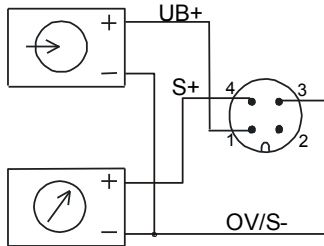

940E04

Cable out

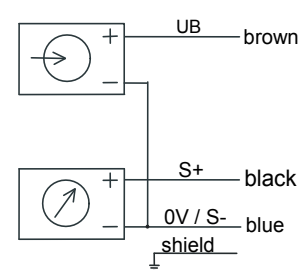

940E06

Pin assignment M12x1 (4 pole)

Electrical connection	4...20 mA (2-wire)		0...10 VDC (3-wire)	
	Pin	Cable end	Pin	Cable end
Supply: (UB+)	1	brown	1	brown
Supply: (0V)	3	blue	3	blue
Signal: (+)	1	brown	4	black
Signal: (-)	3	blue	3	blue
⊕	M12x1 thread	screen	M12x1 thread	screen

Modifications reserved